

# Member Input Sought on Draft HF Band Plan Proposals

Last year the ARRL HF Band Planning Committee sought suggestions on how the growing variety of HF data modes could coexist more compatibly. Review of some 400 comments resulted in a set of “strawman” proposals for updates to the ARRL HF band plans. Here they are, for another round of input from our membership.

**David Sumner, K1ZZ**  
ARRL Chief Executive Officer

At its January 2014 meeting, the ARRL Board of Directors instructed the HF Band Planning Committee “...to reach out to membership regarding concerns pertaining to the increasing popularity of data modes, and furthermore investigate and suggest ways to use spectrum so that these data modes may compatibly coexist with each other.” The committee’s report to the July 2014 meeting of the Board provided an overview of some 400 comments received in response to a solicitation made in early March on the ARRL website and in *The ARRL Letter*.

During October and November 2014, under the leadership of First Vice President Rick Roderick, K5UR, the committee conducted a review of the band plans<sup>1</sup> for the 160 through 10 meter bands, with the exception of 60 meters, in a series of six teleconferences. The committee concluded that most of the concerns voiced by members could be addressed by modest adjustments to the existing band plans, and mainly by confining data modes with bandwidths greater than 500 Hz to the FCC-designated segments for automatically controlled digital stations (ACDS) and to parts of the RTTY/data subbands above those segments. The committee’s conclusions, band by band, are shown in the accompanying figures and discussed below. Once member feedback has been received and analyzed, the committee will make its final recommendations to the Board.

**Important note:** Nothing described here is cast in stone. Please tell us what you like and don’t like, using the feedback mechanism described at the end

of the article. Band plans are voluntary guidelines; observing the FCC Rules is mandatory. If you haven’t read Part 97 of the FCC Rules recently, give yourself a refresher — especially §§ 97.221, 97.301, 97.305, and 97.307. For additional background on band plans, see page 9 of the March 2015 issue of *QST*.

## An Explanation of the Figures

Only the “RTTY/data” subbands — that is, the portions of the band where RTTY and data are permitted...are depicted here. The “phone/image” subbands are not shown. CW is permitted throughout the bands. The following abbreviations are used:

**ACDS:** Automatically controlled digital stations (by FCC Rule; see §97.221(b))

**CW (G, A, E):** Segment available only to General, Advanced, and Amateur Extra class (by FCC Rule; see §97.301)

**Narrow RTTY/Data:** Bandwidth of no more than 500 Hz

**“Packet”:** Current band plan specifies packet, but wider variety of data modes in use

**RTTY/Data:** Bandwidth up to 2700

Hz, otherwise limited by FCC Rule (see §97.307(f))

**Wide RTTY/Data:** Bandwidth 500 – 2700 Hz, otherwise limited by FCC Rule (see §97.307(f))

A maximum bandwidth of 2700 Hz for data emissions would be consistent with the IARU Region 1 and Region 2 band plans.<sup>2,3,4</sup> In the absence of an FCC-prescribed bandwidth limit, some limit on bandwidth is needed in the ARRL band plans.

## 160 Meters

The existing 160 meter band plan was reaffirmed by the Board as recently as January 2008. The committee found no reason to recommend changes at this time.

## 80 Meters (see Figure 1)

The committee concluded that the FCC’s action in 2006 to reduce the 80 meter RTTY/data subband from 250 kHz to 100 kHz and to limit access to 3600 – 3700 kHz only to Amateur Extra class licensees has created significant and unnecessary difficulties for CW, RTTY, and data operators, and has left 3600 – 3700 kHz underutilized. Unless and until the

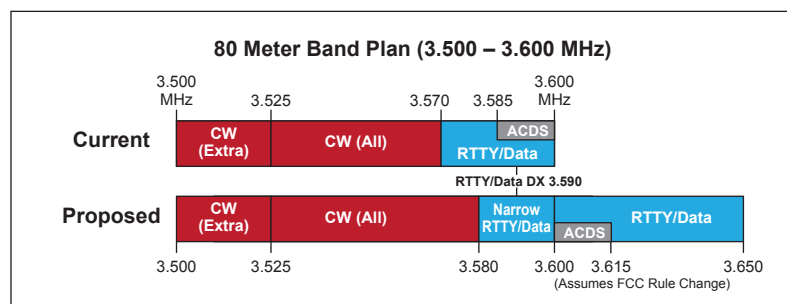

Figure 1 — Proposed 80 meter band plan.

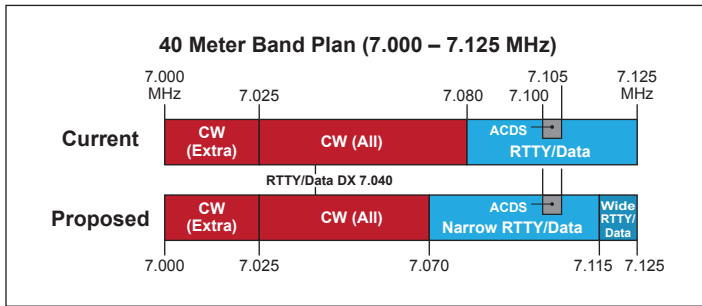

Figure 2 — Proposed 40 meter band plan.

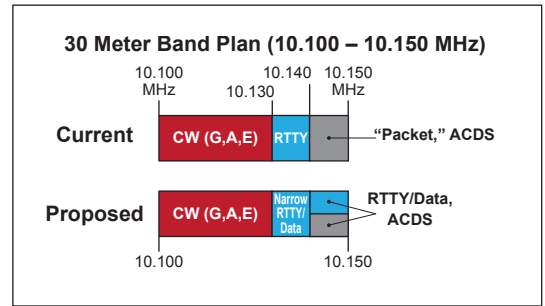

Figure 3 — Proposed 30 meter band plan.

FCC Rules are modified, changes in the band plan for 3500 – 3600 kHz will not improve the situation. This conclusion was supported by numerous comments from members.

Accordingly, the committee has recommended that the FCC be petitioned to move the boundary between the 80 meter RTTY/data band and the 75 meter phone/image band from 3600 to 3650 kHz, with the 3600 – 3650 kHz segment restored to General and Advanced licensees. Members are asked to comment on this, as well as on whether or not the ARRL should petition for these related FCC rules changes:

- Shift the band segment for automatically controlled digital (data) stations (ACDS) from 3585 – 3600 kHz to 3600 – 3615 kHz. (While it was 3620 – 3635 kHz before 2006, 3600 – 3615 kHz would be consistent with the IARU Region 1 and Region 2 band plans.)
- Extend the current Novice/Technician CW segment from 3525 – 3600 to 3525 – 3650 kHz. (While Novice/Tech CW activity is very limited, this change would make 80 meters consistent with 40 and 15 meters where Novices and Techs can operate CW throughout the General/Advanced portions of the RTTY/data subbands.)

- Add 80 meter RTTY/data privileges for Novices and Technicians.

If the FCC can be persuaded to make the change from 3600 to 3650 kHz, it would be desirable to shift the boundary between CW and RTTY/data in the ARRL band plan from 3570 to 3580 kHz in order to be consistent with the Region 1 and Region 2 band plans. This would provide an opportunity to resolve a conflict between W1AW CW transmissions on 3581.5 kHz to PSK31 activity near that frequency by shifting the W1AW frequency below 3580 kHz. Previous attempts to find a better CW frequency for W1AW failed after the FCC’s ill-considered 2006 action because so much CW activity, including traffic nets, had to be squeezed into 3525 – 3570 kHz.

#### 40 Meters (see Figure 2)

Of all of the HF bands, 40 meters has the least global consistency in band planning. This is the result of amateurs having been limited to 7000 – 7100 kHz in Regions 1 and 3 prior to 2009 and to 7000 – 7200 kHz today.

In the rest of the world, including most of Region 2, data modes operate below 7060 kHz. The Region 1 and Region 2 band plans provide for ACDS at 7047 – 7050

kHz (up to 500 Hz bandwidth) and 7050 – 7053 kHz (up to 2700 Hz bandwidth, ie, a single channel).

After reviewing members’ comments, and bearing in mind the fact that most communication on 40 meters by American amateurs is with other stations in North America and not DX, the committee concluded that it is not realistic to try to bring the ARRL band plan for 40 meters into alignment with the rest of the world. While 7040 kHz is recognized as a RTTY/data DX frequency in the band plan, the best place for other RTTY/data activity in this country is above 7070 kHz.

Currently the “Considerate Operator’s Frequency Guide” (COFG) that is published occasionally in *QST* and is available on the ARRL website shows 7070 – 7125 kHz for RTTY/data, while the ARRL band plan shows 7080 – 7125 kHz.<sup>4</sup> The committee proposes that the band plan be aligned with the COFG. Within that range the FCC-mandated ACDS segment is 7100 – 7105 kHz. In order to put “wide” (greater than 500 Hz bandwidth) data as far as possible from narrowband activity the committee proposes that non-ACDS “wide” activity take place at 7115 – 7125 kHz.

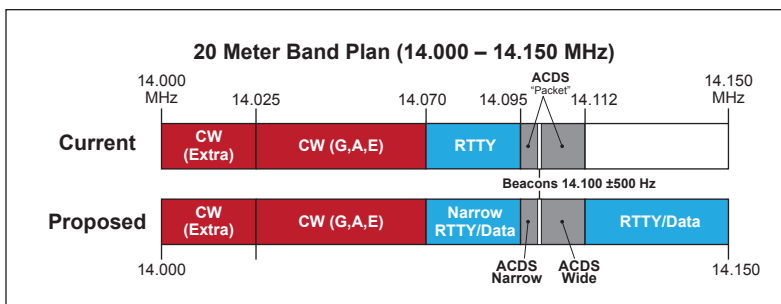

Figure 4 — Proposed 20 meter band plan.

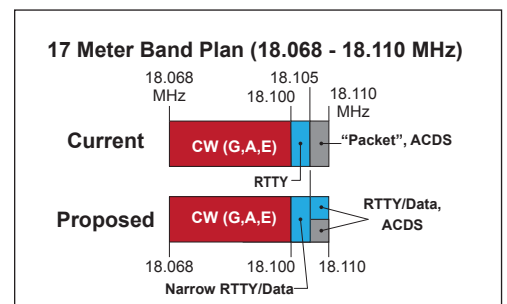

Figure 5 — Proposed 17 meter band plan.

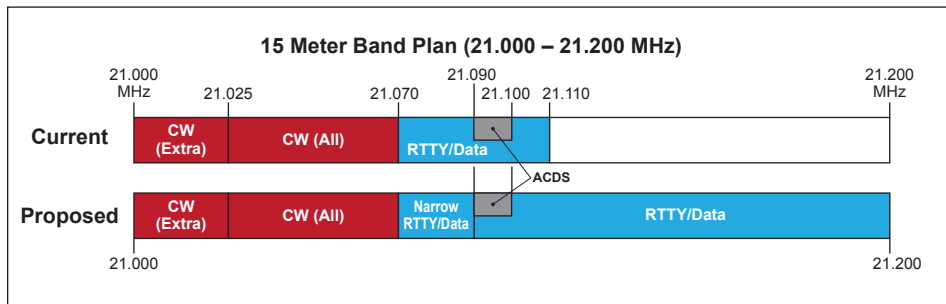

Figure 6 — Proposed 15 meter band plan.

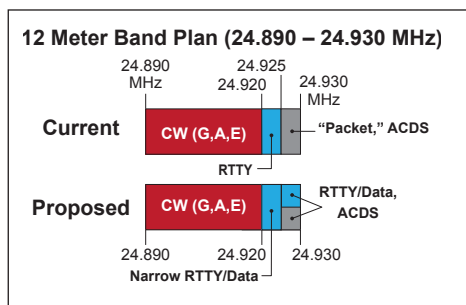

Figure 7 — Proposed 12 meter band plan.

### 30 Meters (see Figure 3)

The FCC-mandated ACDS segment of this band is 10.140 – 10.150 MHz. The committee recommends that “wide” data be confined to this segment and separated from other RTTY/data at 10.130 – 10.140 MHz.

### 20 Meters (see Figure 4)

The FCC-mandated ACDS segments of 20 meters are 14.095 – 14.0995 MHz and 14.1005 – 14.112 MHz. The 1 kHz in between is set aside for the IARU/ NCDXF beacon network. The committee recommends using the beacon frequency as a “hard break” line between “wide” ACDS in the upper segment and “narrow”

ACDS in the lower segment. The recommended segment for RTTY and narrowband data is 14.070 – 14.095 MHz. It should be noted that so-called “weak signal” data modes (PSK31, JT65A, JT9, etc.) are used between 14.070 and 14.078 MHz; these signals may not be audible to other operators. While the current band plan does not show RTTY/data above 14.112 MHz, the committee suggests this as the best place for non-ACDS “wide” RTTY/data.

### 17 Meters (see Figure 5)

The committee recommends that “wide” data be confined to the FCC-mandated ACDS segment of 18.105 – 18.110 MHz and separated from “narrow” RTTY/data at 18.100 – 18.105 MHz. The FCC rules do not permit RTTY/data above 18.110 MHz so the options for this band are limited.

### 15 Meters (see Figure 6)

The ARRL band plan puts RTTY/data at 21.070 – 21.110 MHz. The committee recommends that 21.070 – 21.090 MHz be used for “narrow” RTTY/data, the FCC-mandated ACDS segment of 21.090 – 21.100 MHz be used for both “narrow”

and “wide” ACDS, and any additional “wide” data activity take place only above 21.100 MHz.

In addition, the Board asks that members comment on the desirability of petitioning the FCC to add RTTY/data privileges for Novices and Technicians in their existing 15 meter band, in which they are now limited to CW operation.

### 12 Meters (see Figure 7)

The committee recommends that “wide” data be confined to the FCC-mandated ACDS segment of 24.925 – 24.930 MHz and separated from “narrow” RTTY/data at 24.920 – 24.925 MHz. The FCC rules do not permit RTTY/data above 24.930 MHz so the options for this band are limited.

### 10 Meters (see Figure 8)

The FCC-mandated segment for ACDS is 28.120 – 28.189 MHz. The committee recommends that “wide” data be confined to this segment and separated from “narrow” RTTY/data at 28.070 – 28.120 MHz.

### How to Comment

The ARRL has established a web page to make it easy to record your preferences and comments. You will find it at [www.arrrl.org/bandplan](http://www.arrrl.org/bandplan). If you feel that you need to submit comments in a longer, more detailed form, you can e-mail them to [bandplan@arrrl.org](mailto:bandplan@arrrl.org).

The comment deadline is **April 19, 2015**. This should give the HF Band Planning Committee sufficient time to analyze members’ input and prepare its final report prior to the July 17 – 18 meeting of the Board.

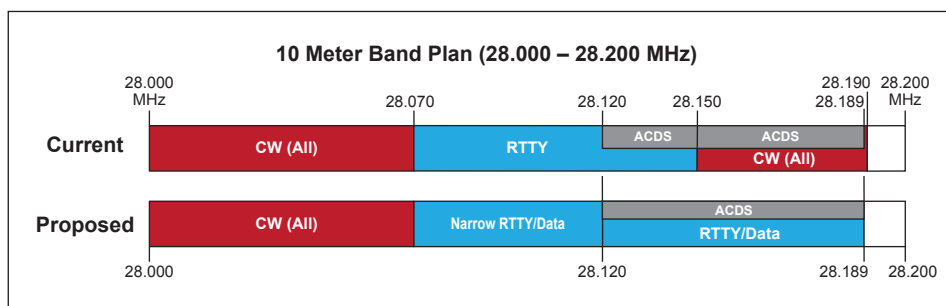

Figure 8 — Proposed 10 meter band plan.

### References

- <sup>1</sup>ARRL band plan: [www.arrrl.org/band-plan](http://www.arrrl.org/band-plan)
- <sup>2</sup>IARU Region 1 band plan: [www.iaru-r1.org/index.php?option=com\\_content&view=article&id=305&Itemid=210](http://www.iaru-r1.org/index.php?option=com_content&view=article&id=305&Itemid=210)
- <sup>3</sup>IARU Region 2 band plan: [www.iaru-r2.org/band-plan/](http://www.iaru-r2.org/band-plan/). Also see the IARU Region 3 band plan at [iaru-r3.org/r3band-plan.doc](http://iaru-r3.org/r3band-plan.doc)
- <sup>4</sup>Considerate Operator’s Frequency Guide: [www.arrrl.org/considerate-operator](http://www.arrrl.org/considerate-operator)